

■ **INTRODUCTION:**

The CE8304 is a high-frequency boost converter dedicated for small to medium LCD bias supply and white LED backlight supplies. The device is ideal to generate output voltages up to 28V from a dual cell NiMH/NiCd or a single cell Li-ion battery. The part can also be used to generate standard 3.3V/5V to 12V power conversions.

The CE8304 operates with a switching frequency up to 1MHz. This allows the use of small external components using ceramic as well as tantalum output capacitors. Together with the small package, the CE8304 gives a very small overall solution size. The CE8304 has an internal 400mA switch current limit, offering low output voltage ripple and allows the use of a small form factor inductor for low power applications. The low quiescent current (20µA TYP) together with an optimized control scheme, allows device operation at very high efficiencies over the entire load current range.

The CE8304 is available in DFN2×2-6, SOT23-6 SOT23-5 packages. It operates over an ambient temperature range of -40°C to +85°C.

■ **APPLICATIONS:**

- LCD Bias Supply
- White-LED Supply for LCD Backlights
- Digital Still Camera
- PDAs, Organizers, and Handheld PCs
- Cellular Phones
- Internet Audio Player
- Standard 3.3V/5V to 12V Conversion

■ **FEATURES:**

- Input Voltage Range: 2.0V to 5.5V
- Adjustable Output Voltage Range up to 28V
- 400mA Internal Switch Current
- Up to 1MHz Switching Frequency
- 20µA Typical No Load Quiescent Current
- 0.1µA Typical Shutdown Current
- Internal Soft-Start Function
- -40°C to +85°C Operating Temperature Range
- Available in Green DFN2×2-6, SOT23-6 and SOT23-5 Packages

■ **ORDERING INFORMATION**

CE8304①②

DESIGNATOR	SYMBOL	DESCRIPTION
①	A	Standard
②	E	Package:SOT23-6
	FB6	Package:DFN2X2-6
	M	Package:SOT23-5

■ TYPICAL APPLICATION CIRCUIT

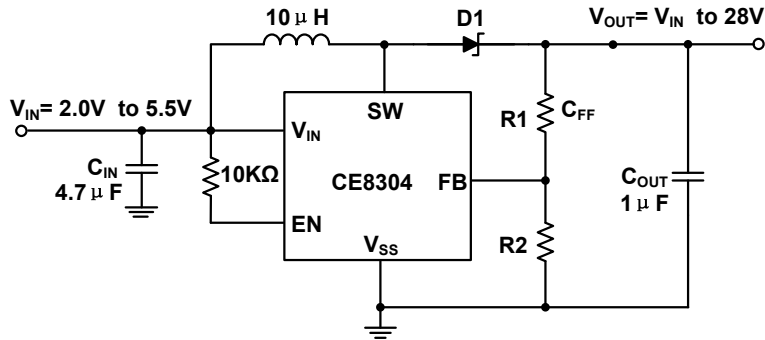
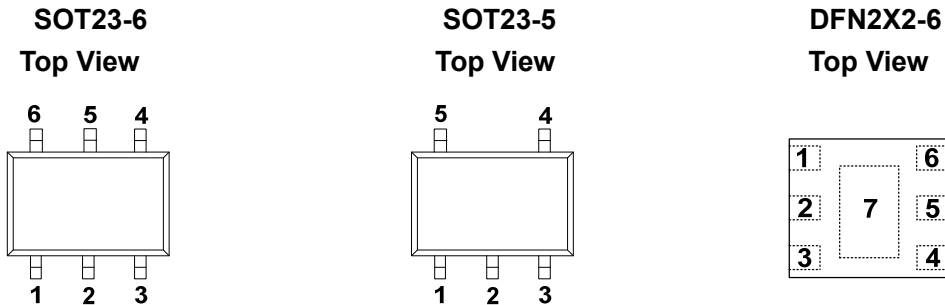

Figure 1 Standard Application Circuit

■ PIN CONFIGURATION



PIN				NAME	DESCRIPTION
SOT23-6	SOT23-5	DFN2X2-6			
E	M	FB6	FB6B		
3	1	6	4	SW	Switch Pin. Switch Pin. It is connected to the drain of the internal power MOSFET. Connect this pin to the inductor and Schottky diode.
4	2	1	3	GND	Ground
6	3	4	1	FB	Feedback Pin. Feedback Pin. Connect this pin to the external voltage divider to program the desired output voltage.
2	4	3	5	EN	Chip Enable. Enable Pin. Pulling this pin to ground forces the device into shutdown mode reducing the supply current to less than 1μA. This pin should not be left floating and needs to be terminated.
1	5	2	6	VIN	Chip Supply Pin. Power Supply. Must be closely decoupled to GND with a capacitor
5	-	5	2	NC	No Connection
-	-	7	7	Exposed Pad	Power Ground Exposed Pad. Must be connected to GND plane.

■ ABSOLUTE MAXIMUM RATINGS

(Unless otherwise specified, $T_A=25^{\circ}\text{C}$)⁽¹⁾

PARAMETER	SYMBOL	RATINGS	UNITS
Supply Voltage range	V_{IN}	-0.3~7	V
SW Switch Voltage		32	V
EN, FB, Voltage		-0.3~ V_{IN}	V
Power Dissipation	SOT23-5	400	mW
	DFN2X2-6	500	mW
	SOT23-6	400	mW
Operating Temperature Range		-40~85	$^{\circ}\text{C}$
Operating Junction Temperature Range	T_j	150	$^{\circ}\text{C}$
Storage Temperature	T_{stg}	-65~150	$^{\circ}\text{C}$
Lead Temperature(Soldering, 10 sec)	T_{solder}	260	$^{\circ}\text{C}$
ESD rating ⁽⁵⁾	Human Body Model - (HBM)	4000	V
	Machine Model- (MM)	250	V

Note:

Stresses beyond those listed under “Absolute Maximum Ratings” may cause permanent damage to the device. These are stress ratings only, and functional operation of the device at these or any other conditions beyond those indicated in the operational sections of the specifications is not implied. Exposure to absolute maximum rating conditions for extended periods may affect device reliability.

CAUTION

This integrated circuit can be damaged by ESD if you don't pay attention to ESD protection. Chippower recommends that all integrated circuits be handled with appropriate precautions. Failure to observe proper handling and installation procedures can cause damage. ESD damage can range from subtle performance degradation to complete device failure. Precision integrated circuits may be more susceptible to damage because very small parametric changes could cause the device not to meet its published specifications.

■ ELECTRICAL CHARACTERISTICS

($V_{IN} = 2.4V$, $EN = V_{IN}$, $C_{IN} = 4.7\mu F$, $C_{OUT} = 1\mu F$, $L = 10\mu H$, $T_A = -40^\circ C$ to $+85^\circ C$. Typical values are at $T_A = +25^\circ C$, unless otherwise noted.)

PARAMETER	SYMBOL	CONDITIONS	MIN	TYP ⁽¹⁾	MAX	UNITS
SUPPLY						
Input Supply Range	V_{IN}		2.0		5.5	V
Shutdown Current	I_{SD}	$EN = GND$		0.1	1	μA
Operating Quiescent Current	I_Q	$I_{OUT} = 0mA$, not switching, $V_{FB} = 1.3V$		20	35	μA
Under-Voltage Lockout Threshold	V_{UVLO}			1.5	1.65	V
ENABLE						
EN Input High Voltage	V_{IH}		1.5			V
EN Input Low Voltage	V_{IL}				0.4	V
EN Input Leakage Current		$EN=GND$ or V_{IN}		0.1	1	μA
POWER SWITCH AND CURRENT LIMIT						
Maximum Switch Voltage	V_{SW}				29	V
Minimum Off Time	t_{OFF}		270	430	570	ns
Maximum On Time	t_{ON}		4	6	8.5	μs
MOSFET On-Resistance	$R_{DS(ON)}$	$V_{IN} = 2.4V$, $I_{SW} = 200mA$		660	1100	m Ω
MOSFET Leakage Current		$V_{SW} = 28V$			1	μA
Switch Current Limit	I_{LIM}		210	400	500	mA
OUTPUT						
Adjustable Output Voltage Range	V_{OUT}		V_{IN}		28	V
Feedback Reference Voltage	V_{FB}	$T_A = 25^\circ C$	1.182	1.202	1.223	V
Feedback Leakage Current	I_{FB}	$V_{FB} = 1.3V$			1	μA

■ TYPICAL PERFORMANCE CHARACTERISTICS

($T_A=25^\circ\text{C}$, unless otherwise specified, Test Figure 1 above)

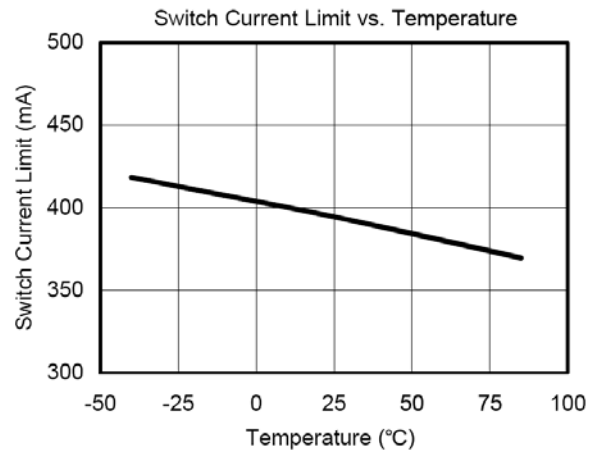
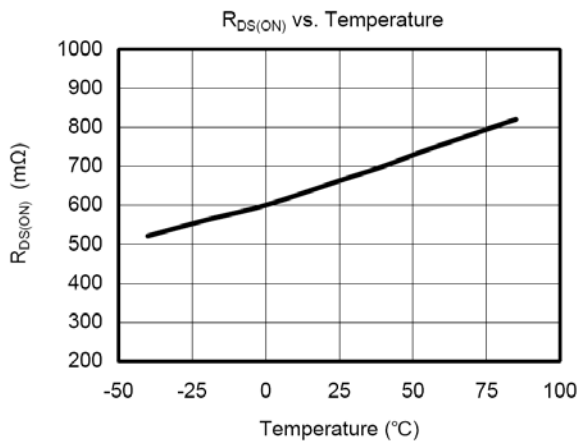
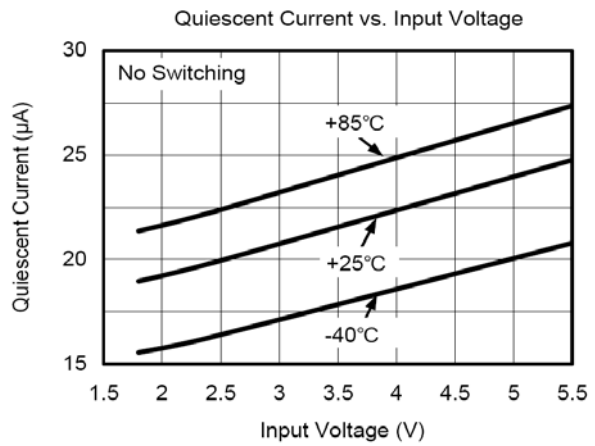
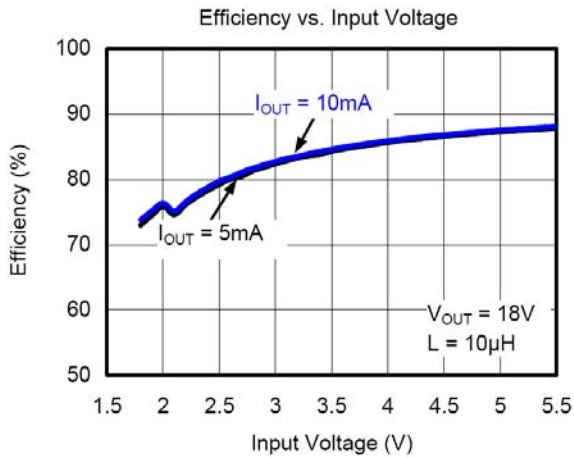
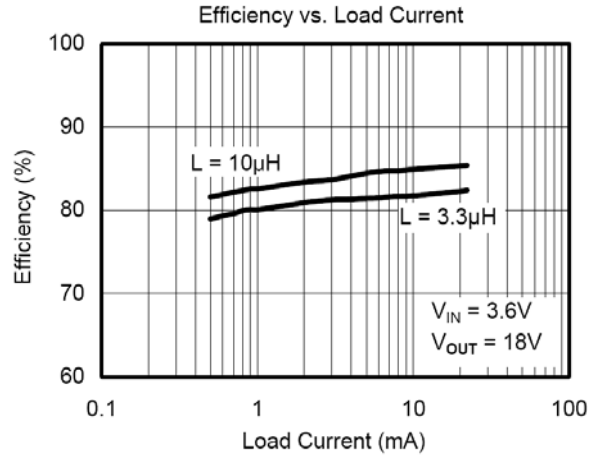
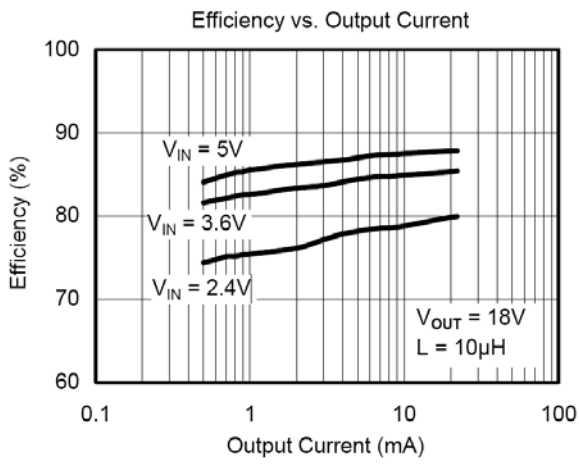

■ TYPICAL PERFORMANCE CHARACTERISTICS

($T_A=25^{\circ}\text{C}$, unless otherwise specified, Test Figure1 above)

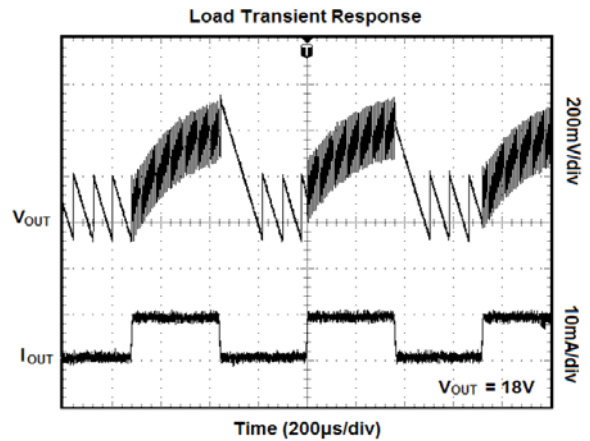
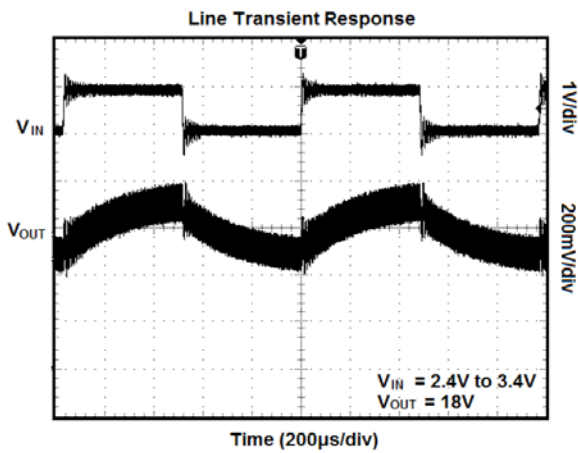
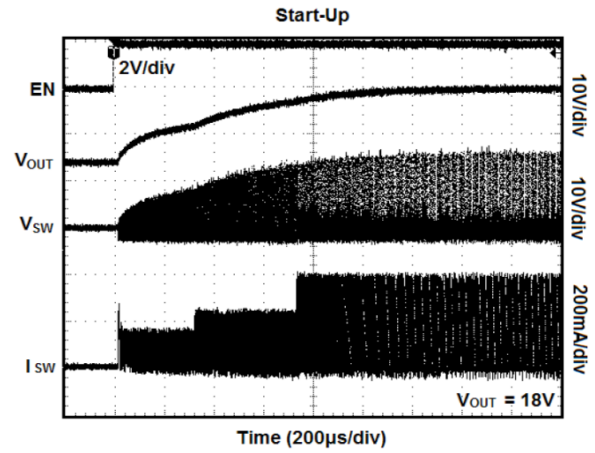
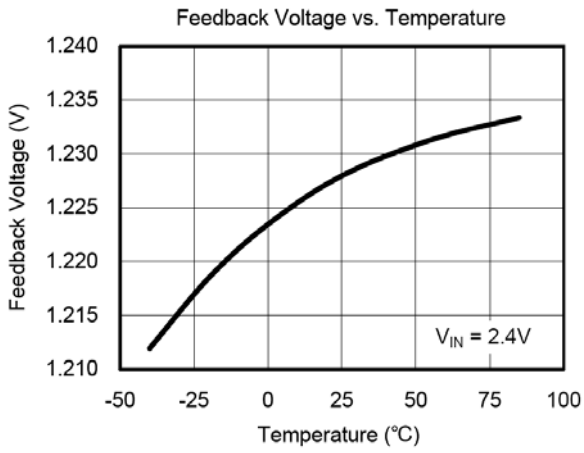

■ DETAILED DESCRIPTION

The CE8304 operates with an input voltage range of 2.0V to 5.5V and can generate output voltages up to 28V. The device operates in a Pulse-Frequency Modulation (PFM) scheme with constant peak current control. This control scheme maintains high efficiency over the entire load current range, and with a switching frequency up to 1MHz, the device enables the use of very small external components.

The converter monitors the output voltage, and as soon as the feedback voltage falls below the reference voltage of typically 1.202V, the internal switch turns on and the current ramps up. The switch turns off as soon as the inductor current reaches the internally set peak current of typically 400mA. The second criteria that turns off the switch is the maximum on time of 6 μ s (TYP). This is just to limit the maximum on time of the converter to cover for extreme conditions. As the switch is turned off the external Schottky diode is forward biased delivering the current to the output. The switch remains off for a minimum of 430ns (TYP), or until the feedback voltage drops below the reference voltage again. Using this PFM peak current control scheme the converter operates in discontinuous conduction mode (DCM) where the switching frequency depends on the output current, which results in very high efficiency over the entire load current range. This regulation scheme is inherently stable, allowing a wider selection range for the inductor and output capacitor.

Peak Current Control

The internal switch turns on until the inductor current reaches the typical DC current limit (I_{LIM}) of 400mA. Due to the internal propagation delay of typically 100ns, the actual current exceeds the DC current limit threshold by a small amount. The typical peak current limit can be calculated:

$$I_{PEAK(TYP)} = I_{LIM} + \frac{V_{IN}}{L} \times 100ns$$

$$I_{LIM} = 400mA$$

The higher the input voltage and the lower, the inductor value, the greater the peak current.

Soft-Start

All inductive step-up converters exhibit high inrush current during start-up if no special precaution is made. This can cause voltage drops at the input rail during start up and may result in an unwanted or early system shutdown.

The CE8304 limits this inrush current by increasing the current limit in two steps starting from $I_{LIM}/3$ for 256 cycles to $I_{LIM}/2$ for the next 256 cycles, and then full current limit.

Enable

Pulling the enable (EN) to ground shuts down the device reducing the shutdown current to 0.1 μ A (TYP). Because there is a conductive path from the input to the output through the inductor and Schottky diode, the output voltage is equal to the input voltage during shutdown. The enable pin needs to be terminated and should not be left floating.

Under-Voltage Lockout

An under-voltage lockout prevents misoperation of the device at input voltages below typically 1.5V. When the input voltage is below the under-voltage threshold, the main switch is turned off.

Thermal Shutdown

An internal thermal shutdown is implemented and turns off the internal MOSFETs when the typical junction temperature of 155°C is exceeded. The thermal shutdown has a hysteresis of typically 20°C. This data is based on statistical means and is not tested during the regular mass production of the IC.

■ APPLICATION INFORMATION

Inductor Selection, Maximum Load Current

Because the PFM peak current control scheme is inherently stable, the inductor value does not affect the stability of the regulator. The selection of the inductor together with the nominal load current, input and output voltage of the application determines the switching frequency of the converter. Depending on the application, inductor values between 2.2µH and 47µH are recommended. The maximum inductor value is determined by the maximum on time of the switch, typically 6µs. The peak current limit of 400mA (TYP) should be reached within this 6µs period for proper operation. The inductor value determines the maximum switching frequency of the converter. Therefore, select the inductor value that ensures the maximum switching frequency at the converter maximum load current is not exceeded. The maximum switching frequency is calculated by the following formula:

$$f_{S(MAX)} = \frac{V_{IN(MIN)} \times (V_{OUT} - V_{IN})}{I_P \times L \times V_{OUT}}$$

Where:

I_P = Peak current

L = Selected inductor value

V_{IN(MIN)} = The highest switching frequency occurs at the minimum input voltage

If the selected inductor value does not exceed the maximum switching frequency of the converter, the next step is to calculate the switching frequency at the nominal load current using the following formula:

$$f_{S(ILOAD)} = \frac{2 \times I_{LOAD} \times (V_{OUT} - V_{IN} + V_d)}{I_P^2 \times L}$$

Where:

I_P = Peak current

L = Selected inductor value

I_{LOAD} = Nominal load current

V_d = Rectifier diode forward voltage (typically 0.3V)

A smaller inductor value gives a higher converter switching frequency, but lowers the efficiency.

The inductor value has less effect on the maximum available load current and is only of secondary order.

The best way to calculate the maximum available load current under certain operating conditions is to estimate the expected converter efficiency at the maximum load current. The maximum load current can then be estimated as follows:

$$I_{LOAD(MAX)} = \eta \frac{I_P^2 \times L \times f_{S(MAX)}}{2 \times (V_{OUT} - V_{IN})}$$

Where:

I_P = Peak current

L = Selected inductor value

f_{S(MAX)} = Maximum switching frequency as calculated previously

η = Expected converter efficiency. Typically 70% to 85%

The maximum load current of the converter is the current at the operation point where the converter starts to enter the continuous conduction mode. Usually the converter should always operate in discontinuous conduction mode.

Last, the selected inductor should have a saturation current that meets the maximum peak current of the converter.

Another important inductor parameter is the DC resistance. The lower the DC resistance, the higher the efficiency of the converter. See Table 1 and the typical applications for the inductor selection.

Table 1. Recommended Inductor for Typical LCD Bias Supply

INDUCTOR	COMPONENT	COMPONENT
10µH	Sumida CR32-100	High efficiency
10µH	Sumida CDRH3D16-100	High efficiency
10µH	Murata LQH4C100K04	High efficiency
4.7µH	Sumida CDRH3D16-4R7	Small solution size
4.7µH	Murata LQH3C4R7M24	Small solution size

■ APPLICATION INFORMATION

Setting the Output Voltage

The output voltage is calculated as:

$$V_{OUT} = 1.202V \times \left(1 + \frac{R_1}{R_2}\right)$$

For battery-powered applications, a high-impedance voltage divider should be used with a typical value for R2 of $\leq 200k\Omega$ and a maximum value for R1 of $2.2M\Omega$. Smaller values might be used to reduce the noise sensitivity of the feedback pin.

A feedforward capacitor across the upper feedback resistor R1 is required to provide sufficient overdrive for the error comparator. Without a feedforward capacitor, or with one whose value is too small, the CE8304 shows double pulses or a pulse burst instead of single pulse at the switch node (SW), causing higher output voltage ripple. If this higher output voltage ripple is acceptable, the feedforward capacitor can be left out.

The lower the switching frequency of the converter, the larger the feedforward capacitor value required. A good starting point is to use a 10pF feedforward capacitor. As a first estimation, the required value for the feedforward capacitor at the operation point can also be calculated using the following formula:

$$C_{FF} = \frac{1}{2 \times \pi \times \frac{f_S}{20} \times R1}$$

Where:

R1 = Upper resistor of voltage divider

f_S = Switching frequency of the converter at the nominal load current (See the Inductor Selection, Maximum Load Current section for calculating the switching frequency)

C_{FF} = Choose a value that comes closest to the result of the calculation

The larger the feedforward capacitor the worse the line regulation of the device. Therefore, when concern for line regulation is paramount, the selected feedforward capacitor should be as small as possible. See the following section for more information about line and load regulation.

Line and Load Regulation

The line regulation of the CE8304 depends on the voltage ripple on the feedback pin. Usually a

45mV peak-to-peak voltage ripple on the feedback pin FB gives good results. Some applications require a very tight line regulation and can only allow a small change in output voltage over a certain input voltage range. If no feedforward capacitor CFF is used across the upper resistor of the voltage feedback divider, the device has the best line regulation. Without the feedforward capacitor the output voltage ripple is higher because the CE8304 shows output voltage bursts instead of single pulses on the switch pin (SW), increasing the output voltage ripple. Increasing the output capacitor value reduces the output voltage ripple.

If a larger output capacitor value is not an option, a feedforward capacitor C_{FF} can be used as described in the previous section. The use of a feedforward capacitor increases the amount of voltage ripple present on the feedback pin (FB). The greater the voltage ripple on the feedback pin ($\geq 45mV$), the worse the line regulation.

There are two ways to improve the line regulation further:

1. Use a smaller inductor value to increase the switching frequency which will lower the output voltage ripple, as well as the voltage ripple on the feedback pin
2. Add a small capacitor from the feedback pin (FB) to ground to reduce the voltage ripple on the feedback pin down to 45mV again. As a starting point, the same capacitor value as selected for the feedforward capacitor C_{FF} can be used.

EN Pin Protection

Power input V_{IN} may exhibit very high voltage spike ($> 2 \times V_{IN}$) under certain situations such as hot swap or hot-insertion. In order to prevent CE8304 from being damaged by high voltage spike and protect EN pin during power-on, when connecting EN to V_{IN} , a pull-up resistor ($> 1k\Omega$) is recommended to be added between EN and V_{IN} instead of connecting them directly (Figure 1).

Output Capacitor Selection

For best output voltage filtering, a low ESR output capacitor is recommended. Ceramic capacitors have a low ESR value but tantalum capacitors can be used as well, depending on the application.

Assuming the converter does not show double pulses or pulse bursts on the switch node (SW), the output voltage ripple can be calculated as:

$$\Delta V_{OUT} = \frac{I_{OUT}}{C_{OUT}} \times \left(\frac{1}{f_{S(IOUT)}} - \frac{I_P \times L}{V_{OUT} + V_d - V_{IN}} \right) + I_P \times ESR$$

where:

I_P = Peak current

L = Selected inductor value

I_{OUT} = Nominal load current

$f_{S(IOUT)}$ = Switching frequency at the nominal load current as calculated previously

V_d = Rectifier diode forward voltage (typically 0.3 V)

C_{OUT} = Selected output capacitor

ESR = Output capacitor ESR value

Input Capacitor Selection

For good input voltage filtering, low ESR ceramic capacitors are recommended. A 4.7 μ F ceramic input capacitor is sufficient for most of the applications. For better input voltage filtering this value can be increased.

Diode Selection

To achieve high efficiency a Schottky diode should be used. The current rating of the diode should meet the peak current rating of the converter as it is calculated in the Peak Current Control section.

Use the maximum value for I_{LIM} for this calculation.

Layout Considerations

Typical for all switching power supplies, the layout is an important step in the design, especially at high peak currents and switching frequencies. If the layout is not carefully done, the regulator might show noise problems and duty cycle jitter.

The input capacitor should be placed as close as possible to the input pin for good input voltage filtering. The inductor and diode should be placed as close as possible to the switch pin to minimize the noise coupling into other circuits. Because the feedback pin and network is a high-impedance circuit, the feedback network should be routed away from the inductor. The feedback pin and feedback network should be shielded with a ground plane or trace to minimize noise coupling into this circuit.

Wide traces should be used for connections. A star ground connection or ground plane minimizes ground shifts and noise.

■ PACKAGING INFORMATION

● SOT23-6 Package Outline Dimensions

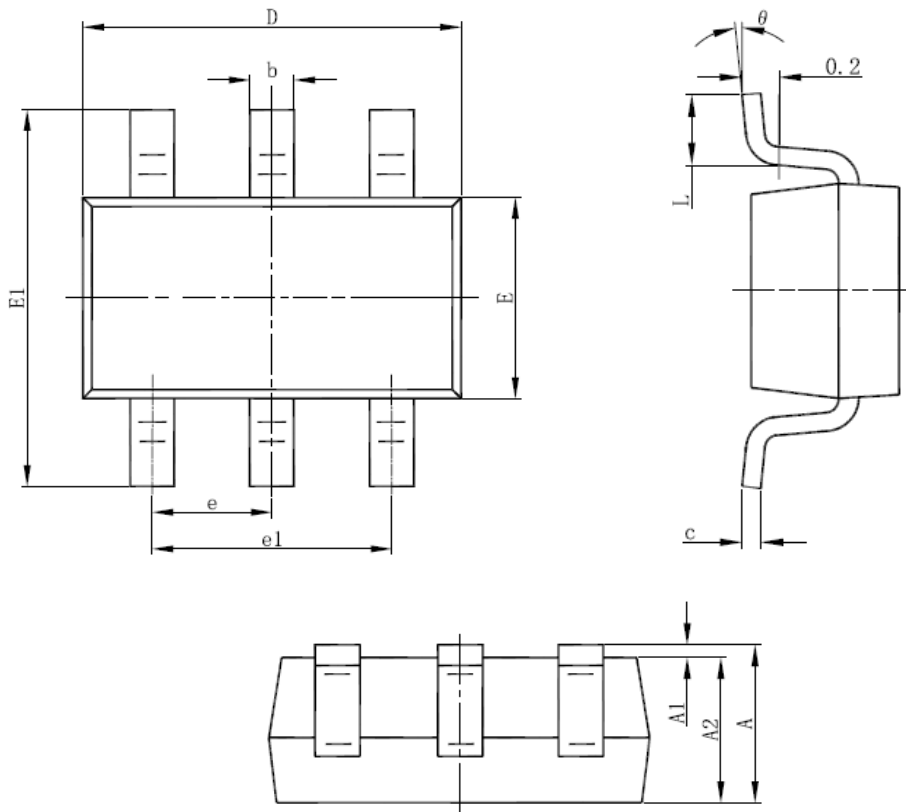

Symbol	Dimensions In Millimeters		Dimensions In Inches	
	Min	Max	Min	Max
A	1.050	1.250	0.041	0.049
A1	0.000	0.100	0.000	0.004
A2	1.050	1.150	0.041	0.045
b	0.300	0.500	0.012	0.020
c	0.100	0.200	0.004	0.008
D	2.820	3.020	0.111	0.119
E	1.500	1.700	0.059	0.067
E1	2.650	2.950	0.104	0.116
e	0.950(BSC)		0.037(BSC)	
e1	1.800	2.000	0.071	0.079
L	0.300	0.600	0.012	0.024
theta	0°	8°	0°	8°

● SOT23-5 Package Outline Dimensions

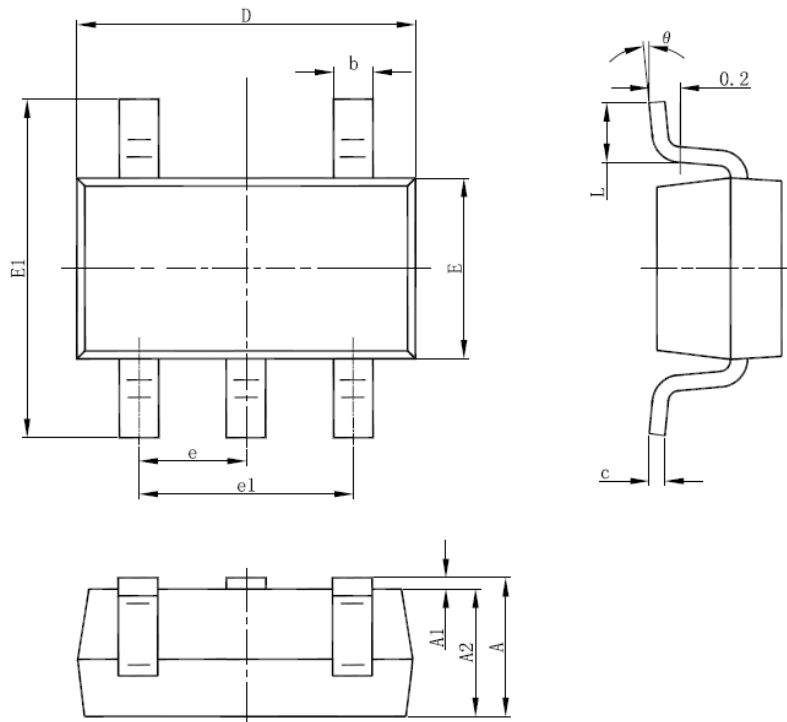

Symbol	Dimensions In Millimeters		Dimensions In Inches	
	Min.	Max.	Min.	Max.
A	1.050	1.250	0.041	0.049
A1	0.000	0.100	0.000	0.004
A2	1.050	1.150	0.041	0.045
b	0.300	0.500	0.012	0.020
c	0.100	0.200	0.004	0.008
D	2.820	3.020	0.111	0.119
E	1.500	1.700	0.059	0.067
E1	2.650	2.950	0.104	0.116
e	0.950(BSC)		0.037(BSC)	
e1	1.800	2.000	0.071	0.079
L	0.300	0.600	0.012	0.024
θ	0°	8°	0°	8°

● DFN2X2-6 Package Outline Dimensions

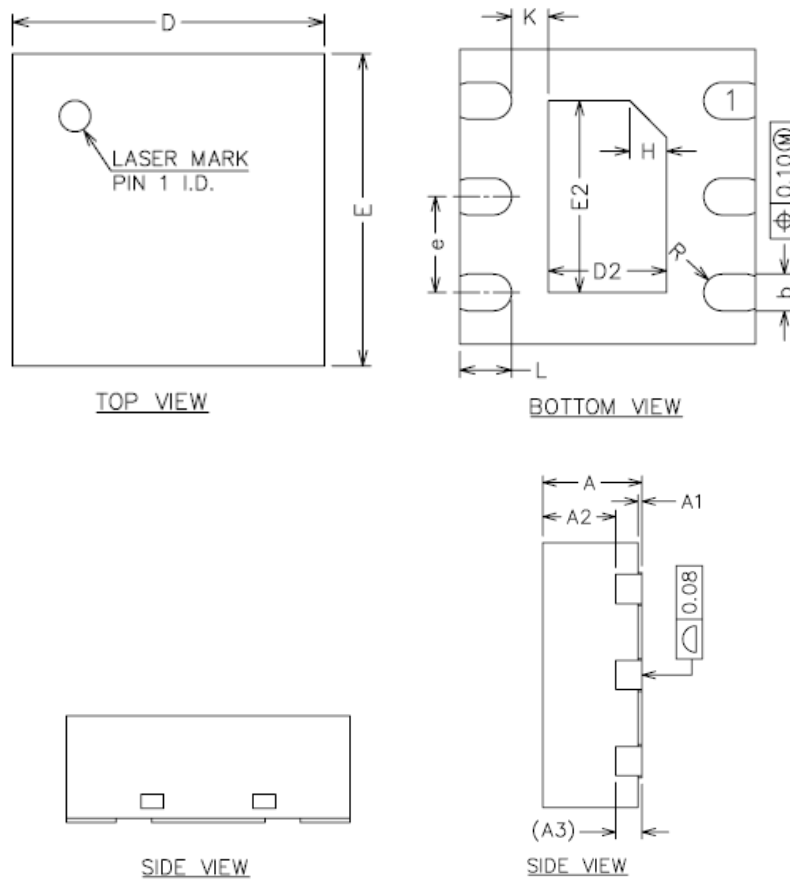

Symbol	Dimensions In Millimeters		
	MIN.	NOM.	MAX.
A	0.70	0.75	0.80
A1	0.00	0.02	0.05
A2	0.50	0.55	0.60
A3	0.20REF		
b	0.20	0.25	0.30
D	1.90	2.00	2.10
E	1.90	2.00	2.10
D2	0.70	0.80	0.90
E2	1.20	1.30	1.40
e	0.55	0.65	0.75
H	0.25REF		
K	0.20	-	-
L	0.30	0.35	0.40
R	0.11	-	-

© Nanjing Chipower Electronics Inc.

Chipower cannot assume responsibility for use of any circuitry other than circuitry entirely embodied in a Chipower product. No circuit patent license, copyrights or other intellectual property rights are implied. Chipower reserves the right to make changes to their products or specifications without notice. Customers are advised to obtain the latest version of relevant information to verify, before placing orders, that information being relied on is current and complete.