

Synchronous Step-Up DC/DC Converter with PFM Control

CE8401 Series

INTRODUCTION

The CE8401 Series is a Synchronous step-up DC/DC Converter with PFM Control.

With the CE8401 Series, a step-up switching DC/DC converter can be configured by using an external coil, capacitor. The built-in MOSFET is turned off by a protection circuit when the voltage at the LX pin exceeds the limit to prevent it from being damaged.

APPLICATIONS

- Digital cameras
- Electronic notebooks and PDAs
- Portable CD/MD players

BLOCK DIAGRAM

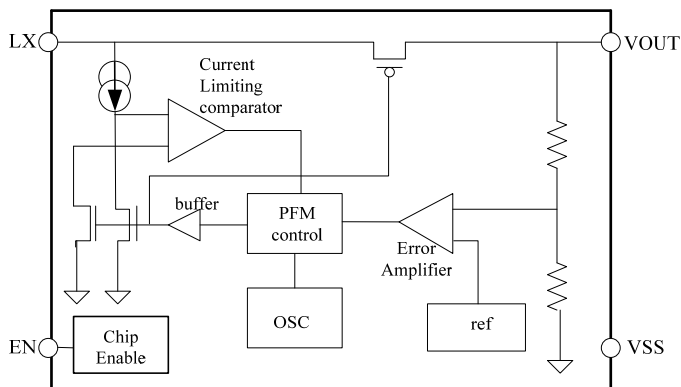

FEATURES

- External parts: Coil, capacitor
- Output voltage: Settable to between 1.8V to 5.5 V in 0.1 V steps
- Maximum Oscillation frequency: 300KHz
- Accuracy of $\pm 2\%$
- High efficiency: 95%

- Cameras, video equipment,
- Communications equipment
- Power supply for microcomputers

ORDER INFORMATION

CE8401①②③④

DESIGNATOR	SYMBOL	DESCRIPTION
①	A	Standard LX
	B	With shutdown, LX
②③	Integer	Output Voltage (1.8~5.5) e.g.: 3.0V=②:3; ③:0
④	M	Package: SOT-23-3/5
	MB	Package: SOT-23
	P	Package: SOT-89
	T	Package: TO92

■ PIN CONFIGURATION

SOT-23
SOT-23-3

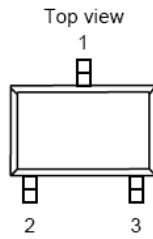

Table 1 CE8401A Series (SOT-23-3/SOT-23 PKG)

PIN NO.	PIN NAME	FUNCTION
1	V_{OUT}	Output voltage pin
2	V_{SS}	GND pin
3	LX	External inductor connection pin

SOT-23-5

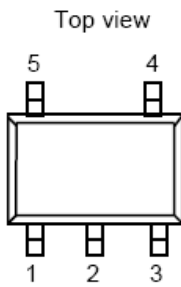

Table 2 CE8401B Series (SOT-23-5 PKG)

PIN NO.	PIN NAME	FUNCTION
1	EN	Shutdown pin “H”: Normal operation “L”: Step-up stopped
2	V_{OUT}	Output voltage pin
3	NC	(N.C.)
4	V_{SS}	GND pin
5	LX	External inductor connection pin

SOT-89-3

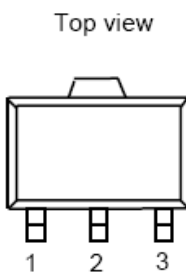

Table 3 CE8401A Series (SOT-89-3 PKG)

PIN NO.	PIN NAME	FUNCTION
1	V_{SS}	GND pin
2	V_{OUT}	Output voltage pin
3	LX	External inductor connection pin

TO-92
Bottom view

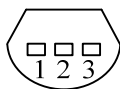

Table 4 CE8401A Series (TO-92 PKG)

PIN NO.	PIN NAME	FUNCTION
1	V_{SS}	GND pin
2	V_{OUT}	Output voltage pin
3	LX	External inductor connection pin

■ ABSOLUTE MAXIMUM RATINGS

(Unless otherwise specified, Ta=25°C)

PARAMETER		SYMBOL	RATINGS	UNITS
V _{OUT} Pin Voltage		V _{OUT}	V _{SS} -0.3 ~ V _{SS} +8	V
EN Pin Voltage		EN	V _{SS} -0.3 ~ V _{SS} +8	V
LX Pin Voltage		V _{LX}	V _{SS} -0.3 ~ V _{SS} +8	V
LX Pin Current		I _{LX}	1000	mA
Power Dissipation	SOT-23	PD	250	mW
	SOT23-3/SOT-23-5		250	mW
	SOT-89-3		500	mW
	TO-92		500	mW
Operating Temperature		T _{opr}	-40 ~+85	°C
Storage Temperature		T _{stg}	-40 ~+125	°C
Soldering Temperature & Time		T _{solder}	260°C, 10s	

■ ELECTRICAL CHARACTERISTICS

(Unless otherwise specified, Ta=25°C)

PARAMETER	SYMBOL	CONDITIONS	MIN	TYP	MAX	UNITS
Output Voltage	V _{OUT}	—	V _{OUT(S)} ×0.98	V _{OUT}	V _{OUT(S)} ×1.02	V
Input Voltage	V _{IN}	V _{OUT} ≤ 3.6 V	0.9	—	5	V
		V _{OUT} > 3.6 V	1.8	—	5	V
Operation Start Voltage	V _{ST1}	I _{OUT} = 1 mA	—	—	0.9	V
Input Current At No Load	I _{SS}	V _{IN} =1.8V, V _{OUT} =3.0V	—	15	-	μA
Current Consumption 2	I _{SS2}	V _{OUT} =V _{OUT} +0.5 V	—	6	10	μA
Current Consumption During Shutdown	I _{SSS}	V _{EN} = 0 V	—	—	1.0	μA
Maximum Oscillation Frequency	f _{OSC}	V _{OUT} = 0.95×V _{OUT} , measure waveform at LX pin	—	300	—	KHz
Duty Ratio 1	Duty1	V _{OUT} = 0.95×V _{OUT} , measure waveform at LX pin	70	78	85	%
Efficiency	EFFI	—	—	90	—	%
Shutdown Pin Input Voltage	V _{SH}	V _{OUT} =0.95×V _{OUT} , judge oscillation at LX pin	0.75	—	—	V
	V _{SL1}	V _{OUT} = 0.95×V _{OUT} , judge stop at LX pin	—	—	0.3	V
Shutdown Pin Input Current	I _{SH}	V _{EN} =6V	-0.1	—	0.1	μA
	I _{SL}	V _{EN} =0V	-0.1	—	0.1	μA

Remark: V_{OUT(S)} specified above is the set output voltage value, and V_{OUT} is the typical value of the actual output voltage.

■ STANDARD CIRCUITS

Component: Inductor: 47uH(Sumida)
Capacitor: 47uF/16V(Tantalum)

1、CE8401A:

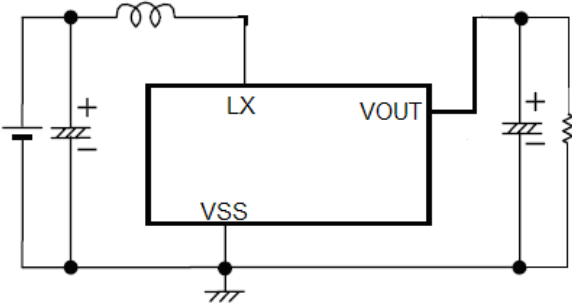

2、CE8401B:

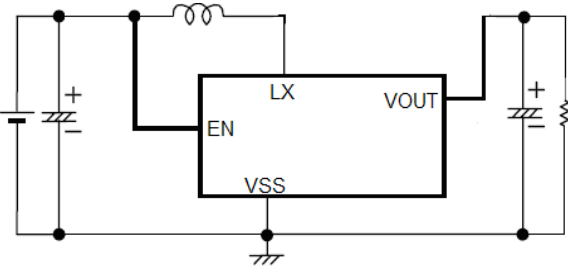

■ TYPICAL PERFORMANCE CHARACTERISTICS

$C_{IN}=C_{OUT}=100\mu F$

$L=47\mu H$

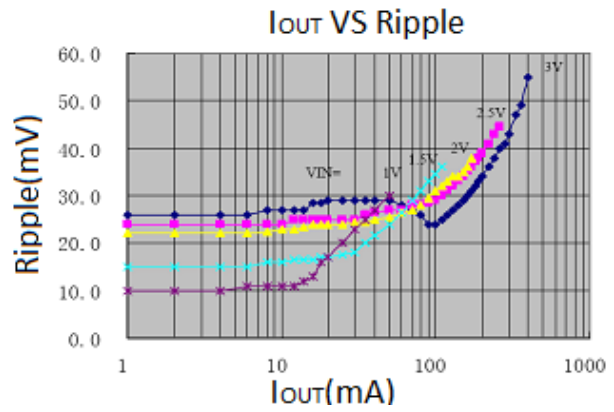
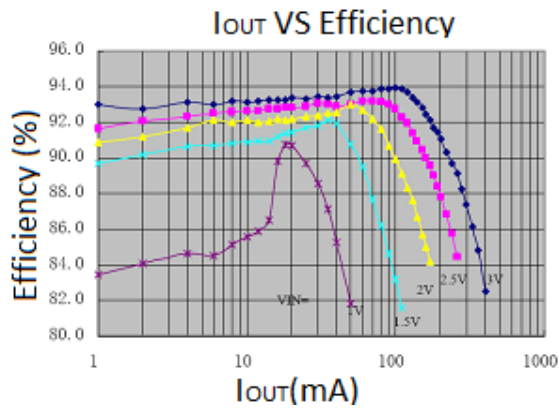
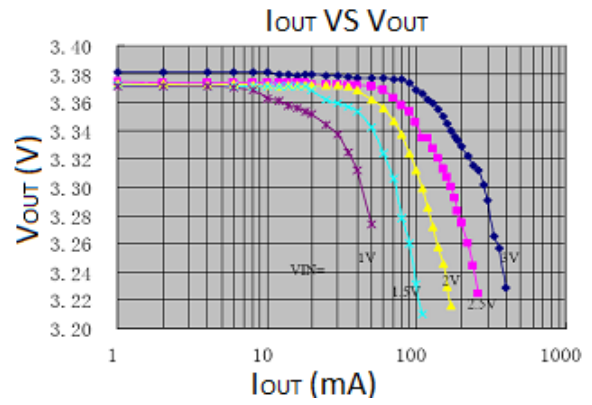
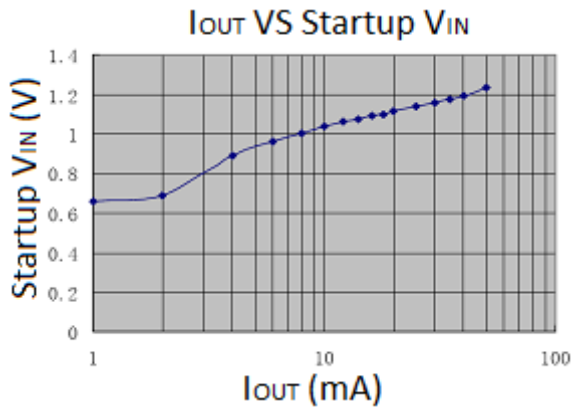

■ PACKAGE INFORMATION

• SOT-23

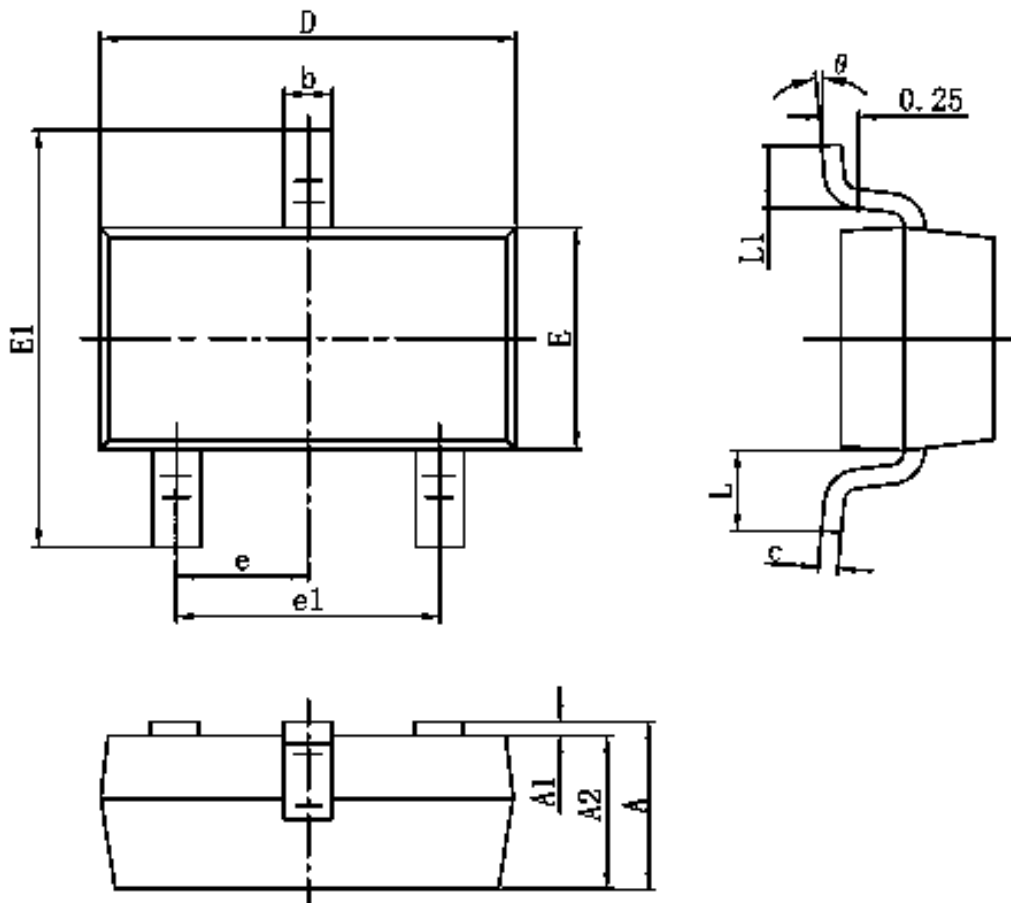

Symbol	Dimensions in Millimeters		Dimensions in Inches	
	Min.	Max.	Min.	Max.
A	0.900	1.150	0.035	0.045
A1	0.000	0.100	0.000	0.004
A2	0.900	1.050	0.035	0.041
b	0.300	0.500	0.012	0.020
c	0.080	0.150	0.003	0.006
D	2.800	3.000	0.110	0.118
E	1.200	1.400	0.047	0.055
E1	2.250	2.550	0.089	0.100
e	0.950 TYP.		0.037 TYP.	
e1	1.800	2.000	0.071	0.079
L	0.550 REF.		0.022 REF.	
L1	0.300	0.500	0.012	0.020
θ	0°	8°	0°	8°

• SOT-23-3

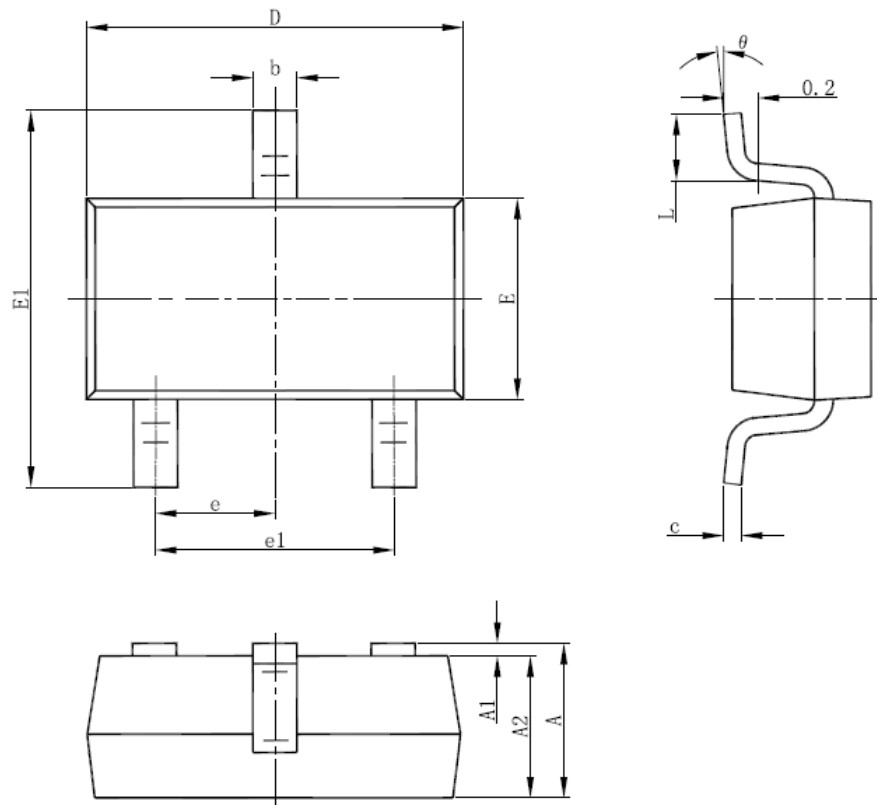

Symbol	Dimensions In Millimeters		Dimensions In Inches	
	Min	Max	Min	Max
A	1.050	1.250	0.041	0.049
A1	0.000	0.100	0.000	0.004
A2	1.050	1.150	0.041	0.045
b	0.300	0.500	0.012	0.020
c	0.100	0.200	0.004	0.008
D	2.820	3.020	0.111	0.119
E	1.500	1.700	0.059	0.067
E1	2.650	2.950	0.104	0.116
e	0.950(BSC)		0.037(BSC)	
e1	1.800	2.000	0.071	0.079
L	0.300	0.600	0.012	0.024
theta	0°	8°	0°	8°

• SOT-23-5

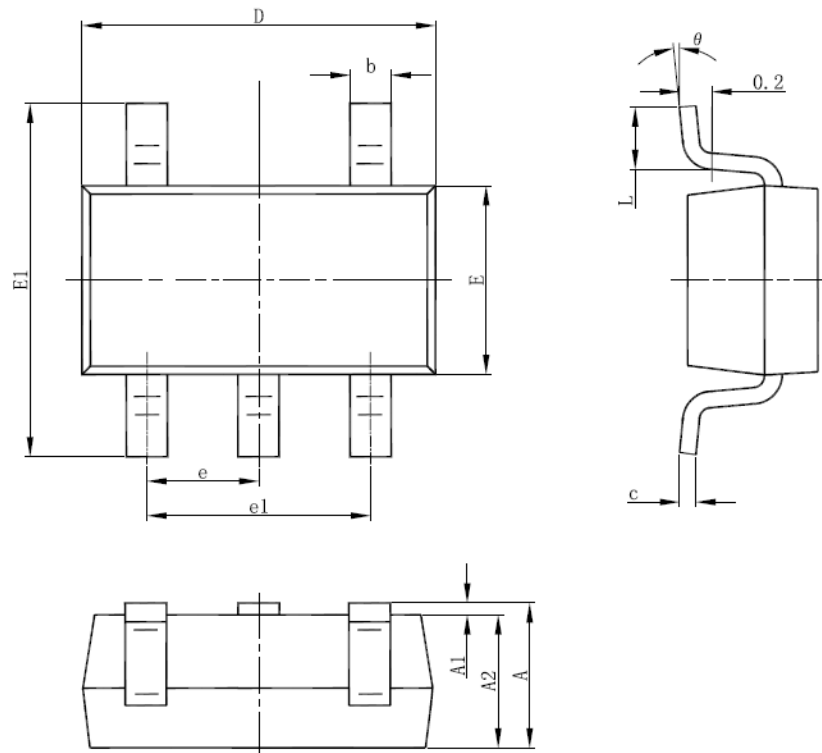

Symbol	Dimensions In Millimeters		Dimensions In Inches	
	Min	Max	Min	Max
A	1.050	1.250	0.041	0.049
A1	0.000	0.100	0.000	0.004
A2	1.050	1.150	0.041	0.045
b	0.300	0.500	0.012	0.020
c	0.100	0.200	0.004	0.008
D	2.820	3.020	0.111	0.119
E	1.500	1.700	0.059	0.067
E1	2.650	2.950	0.104	0.116
e	0.950(BSC)		0.037(BSC)	
e1	1.800	2.000	0.071	0.079
L	0.300	0.600	0.012	0.024
θ	0°	8°	0°	8°

• SOT-89-3

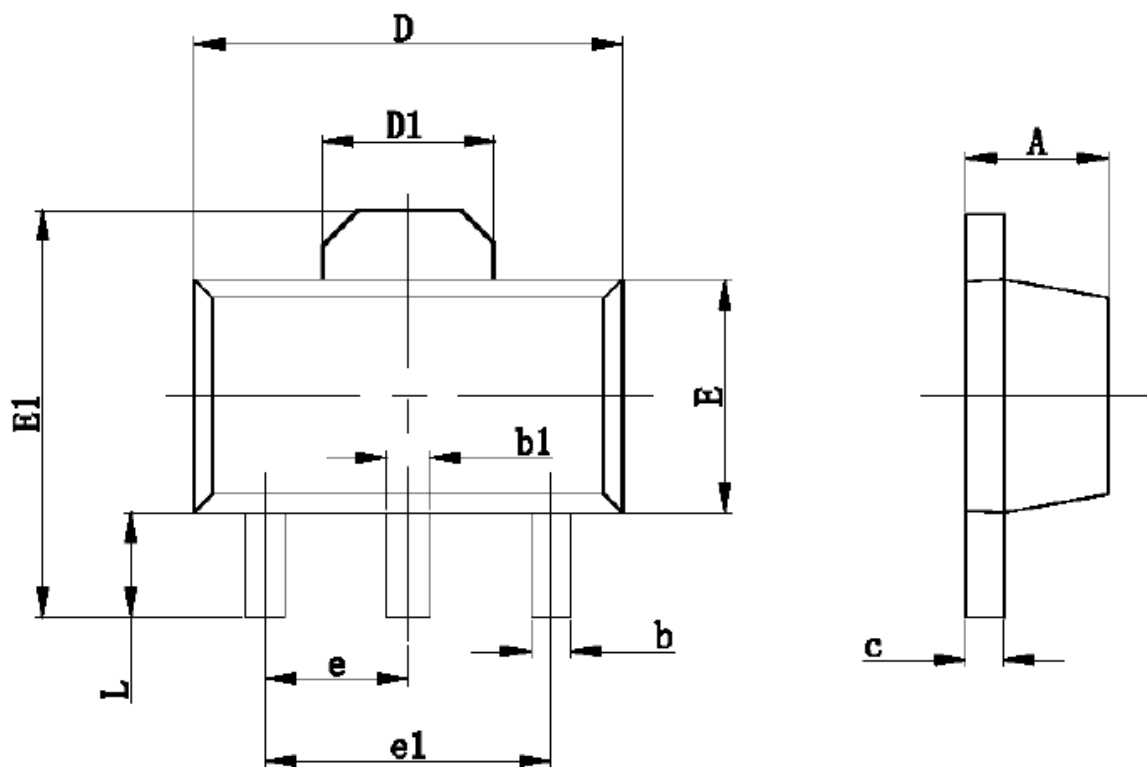

Symbol	Dimensions In Millimeters		Dimensions In Inches	
	Min	Max	Min	Max
A	1.400	1.600	0.055	0.063
b	0.320	0.520	0.013	0.197
b1	0.400	0.580	0.016	0.023
c	0.350	0.440	0.014	0.017
D	4.400	4.600	0.173	0.181
D1	1.550 REF		0.061 REF	
E	2.300	2.600	0.091	0.102
E1	3.940	4.250	0.155	0.167
e	1.500 TYP		0.060 TYP	
e1	3.000 TYP		0.118 TYP	
L	0.900	1.200	0.035	0.047

• TO-92

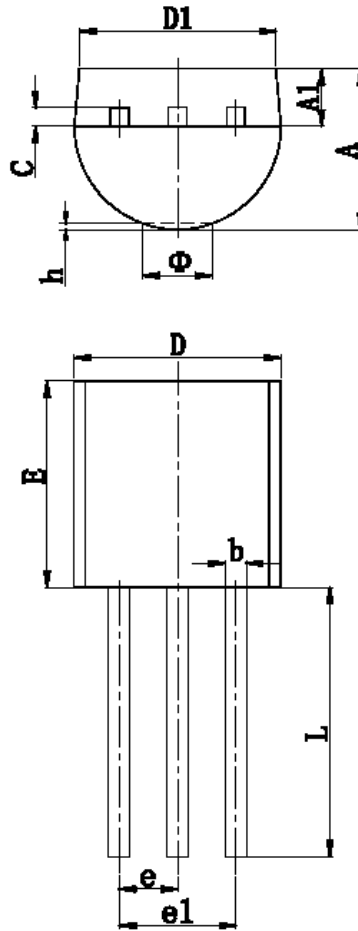

Symbol	Dimensions In Millimeters		Dimensions In Inches	
	Min	Max	Min	Max
A	3.300	3.700	0.130	0.146
A1	1.100	1.400	0.043	0.055
b	0.380	0.550	0.015	0.022
c	0.360	0.510	0.014	0.020
D	4.400	4.700	0.173	0.185
D1	3.430		0.135	
E	4.300	4.700	0.169	0.185
e	1.270 TYP		0.050 TYP	
e1	2.440	2.640	0.096	0.104
L	14.100	14.500	0.555	0.571
Φ		1.600		0.063
h	0.000	0.380	0.000	0.015

© Nanjing Chipower Electronics Inc.

Chipower cannot assume responsibility for use of any circuitry other than circuitry entirely embodied in a Chipower product. No circuit patent license, copyrights or other intellectual property rights are implied. Chipower reserves the right to make changes to their products or specifications without notice. Customers are advised to obtain the latest version of relevant information to verify, before placing orders, that information being relied on is current and complete.