

## 1W/3W High Power Step-down LED Drivers

## CE9302

### ■ INTRODUCTION:

The CE9302 is a step down constant current high brightness LED driver which provide a cost effective design solution for automotive interior/exterior lighting, architectural and ambient lighting, LED bulbs, and other LED illumination applications. The CE9302 operate from a 6.0V to 30V input voltage range. A high-side current-sense resistor adjusts the output current up to 1A and a dedicated DIM input accepts either a DC voltage or a wide range of pulsed dimming. Applying a voltage of 0.3V or lower to the DIM pin turns the output off and switches the device into a low current standby state. A hysteretic control method ensures excellent input supply rejection and fast response during load transients and PWM dimming.

### ■ APPLICATIONS:

- Architecture Detail lighting
- Constant Current Source
- Hand-held lighting
- Portable Consumer Devices

### ■ ORDER INFORMATION:

#### CE9302①②③

DESIGNATOR	SYMBOL	DESCRIPTION
①	A	Standard
②	ES	Package: SOP8-PP
	P	Package: SOT-89-5
③	1	A Type: 95~101mV
	2	B Type: 99~105mV

### ■ FEATURES:

- Up to 97% Efficiency
- Power Supply Voltage: 6.0V-30V
- Simple Low Parts Count
- Maximum PWM Dimming Frequency: 50kHz
- Up to 1MHz Switching Frequency
- Hysteretic Control: No Compensation
- Single Pin on/off and Brightness Control  
Using DC Voltage or PWM Pulse
- Inherent Open Circuit LED Protection
- Typical 5% Output Current Accuracy
- Soft-Start Limit In-Rush Current
- Over-Thermal Protection
- -40°C to +85°C Temperature Range
- space-saving SOT89-5 or SOP8-PP package

■ PIN CONFIGURATION:

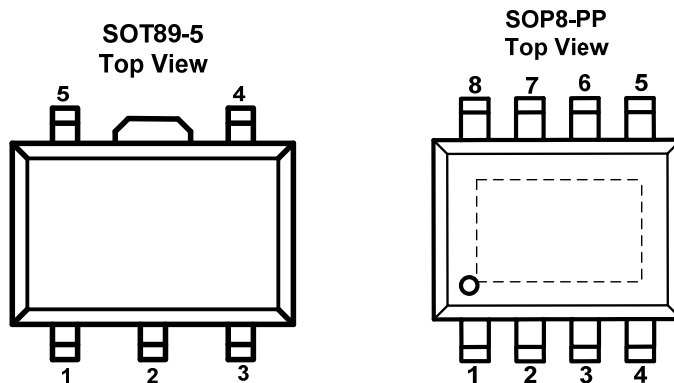

Tabel1. Pin Description

SOT89-5:

PIN NUMBER	PIN NAME	FUNCTION
1	SW	Power Switch Pin
2	GND	Ground
3	DIM	Enable and Dimming Input.
4	CSN	Current Sense Input
5	VIN	Power Supply Input

SOP8-PP:

PIN NUMBER	PIN NAME	FUNCTION
1	CSN	Current Sense Input
2	VIN	Power Supply Input
3	SW	Power Switch Pin
4/5	NC	Not Connect
6	GNDP	Power Ground
7	GND A	Analog Ground
8	DIM	Enable and Dimming Input.

■ BLOCK DIAGRAM

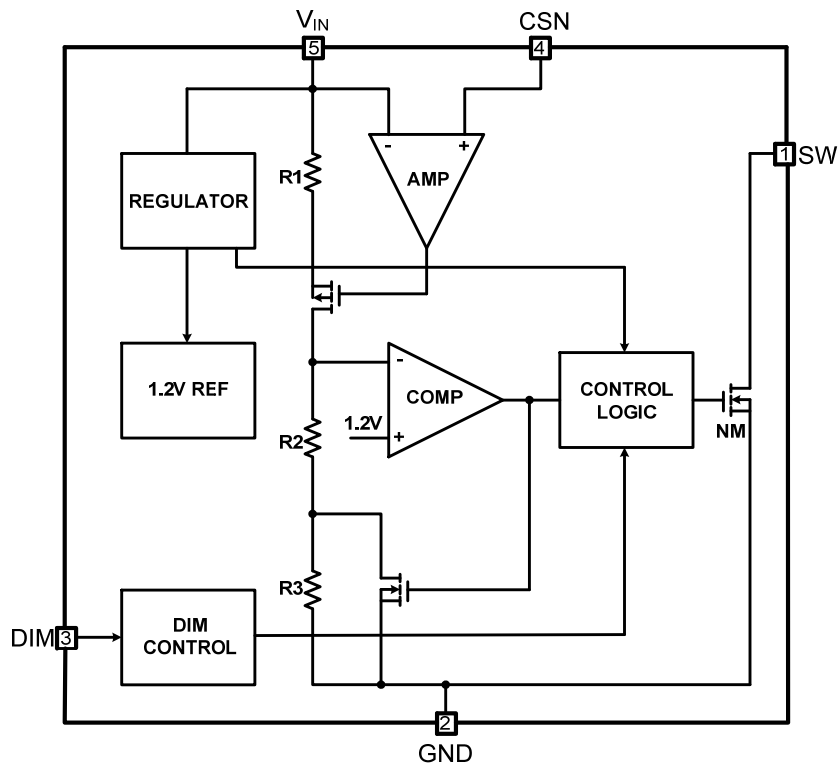

■ ABSOLUTE MAXIMUM RATINGS

(Unless otherwise specified, Ta=25°C)

PARAMETER	SYMBOL	RATINGS	UNITS	
Input Voltage	$V_{IN}$	$V_{SS}-0.3 \sim V_{SS}+45$	V	
SW,CSN Voltage		$V_{SS}-0.3 \sim V_{IN}+0.3$	V	
DIM Voltage		$V_{SS}-0.3 \sim 6.0$	V	
Peak SW Sink and Source Current	$I_{SWMAX}$	1500	mA	
Power Dissipation	SOT-89-5L	$P_d$	500	mW
	SOP8-PP	$P_d$	1000	mW
Operating Temperature	$T_{opr}$	-40~+85	°C	
Junction Temperature	$T_j$	125	°C	
Storage Temperature	$T_{stg}$	-40~+125	°C	
Soldering Temperature & Time	$T_{solder}$	260°C, 10s		

■ ELECTRICAL CHARACTERISTICS

CE9302 ( $V_{IN}=12V$ ,  $T_a=25^\circ C$ , Test Circuit Figure1, unless otherwise specified )

PARAMETER	SYMBOL	CONDITIONS	MIN	TYP	MAX	UNITS
Input Voltage	$V_{IN}$		6.0		30	V
Undervoltage Lockout	$V_{UVLO}$	$V_{IN}$ Falling		5.7		V
Undervoltage Lockout Hysterisis	$V_{UVLO,HYS}$	$V_{IN}$ Rising		0.5		V

Shutdown Current	$I_{SD}$	$V_{DIM} < 0.3V$		75		$\mu A$	
Mean Current Sense Threshold Voltage	$V_{CSN}$	$V_{IN} - V_{CSN}$	A Type	95	98	101	mV
			B Type	99	102	105	mV
Sense Threshold Hysteresis	$V_{CSN\_HYS}$			$\pm 15$		%	
CSN Pin Input Current	$I_{CSN}$	$V_{CSN} = V_{IN} - 0.05$		8		$\mu A$	
Continuous SW Switch Current	$I_{SWMEAN}$				1.2	A	
SW Switch 'On' Resistance	$R_{SW}$			0.6		$\Omega$	
SW Switch Leakage Current	$I_{LEAK}$			0.5	5	$\mu A$	
Internal Supply Voltage	$V_{DIM}$	Dim Floating		5.3		V	
DIM Pull Up Resistor To Internal Supply Voltage	$R_{DIM}$			500		k $\Omega$	
Dim Input Voltage High	$V_{DIM\_H}$		2.5			V	
Dim Input Voltage Low	$V_{DIM\_L}$				0.3	V	
DC Brightness Control	$V_{DIM\_DC}$		0.5		2.5	V	
Max. DIM Frequency	$f_{PWM}$				50	kHz	
Maximum Operating Frequency	$f_{LXmax}$				1	MHz	
Thermal Shutdown Threshold	$T_{SD}$			160		$^{\circ}C$	
Thermal Shutdown Hysteresis	$T_{SD\_HYS}$			20		$^{\circ}C$	

■ TYPICAL APPLICATION CIRCUITS

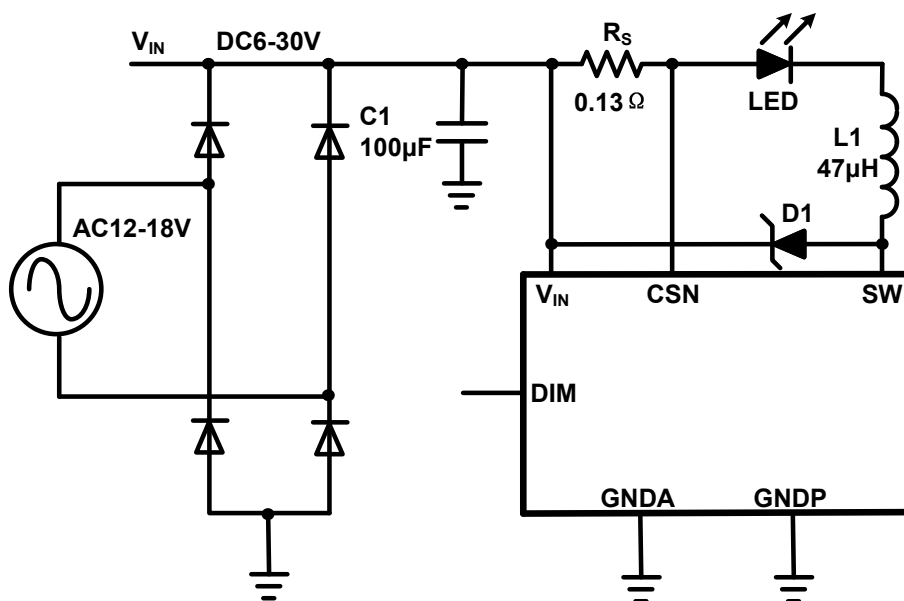

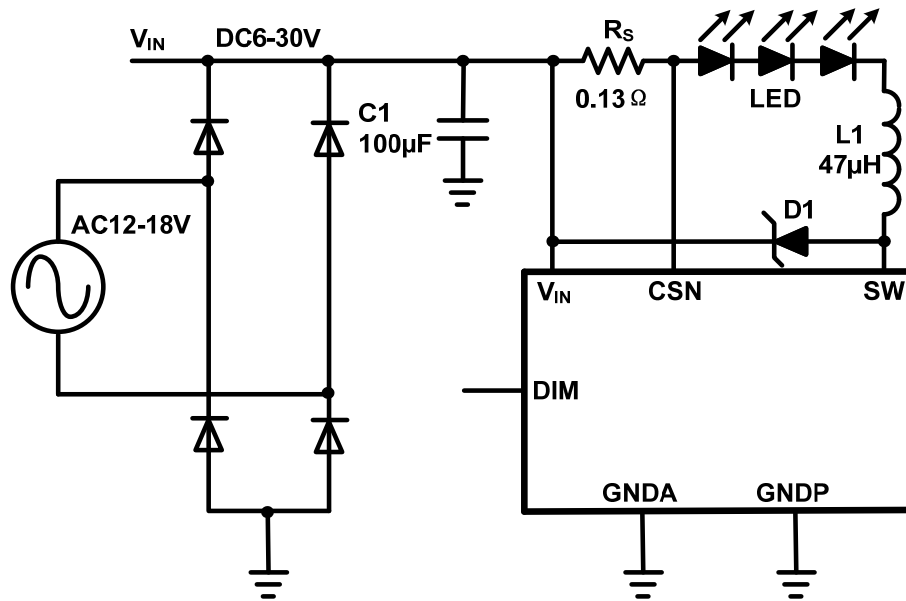

Figure1 Basic Application Circuit

■ OPERATION

The CE9302 is a step-down, constant current, high-brightness LED (HB LED) driver. These devices operate from a 6.0V to 30V input voltage range and deliver up to 1A of output current. A high side current-sense resistor sets the output current and a dedicated PWM dimming input enables pulsed LED dimming over a wide range of brightness levels.

DEVICE OPERATION

The circuit, in conjunction with the coil (L1) and current sense resistor (R<sub>S</sub>), forms a self-oscillating continuous-mode buck converter, refers to **BLOCK DIAGRAM**.

Operation can be best understood by assuming that the DIM pin of the device is active. When input voltage V<sub>IN</sub> is first applied, the initial current in L1 and R<sub>S</sub> is zero and there is no output from the current sense circuit. Under this condition, the (-) input to the comparator is at ground and its output is high. This turns power NM on and

switches the SW pin low, causing current to flow from V<sub>IN</sub> to ground, via R<sub>S</sub>, L1 and the LED(s). The current rises at a rate determined by V<sub>IN</sub> and L1 to produce a voltage ramp across R<sub>S</sub>. The supply referred voltage V<sub>CSN</sub> is forced across internal resistor R1 by the current sense circuit and produces a proportional current in internal resistors R2 and R3. This produces a ground referred rising voltage at the (-) input of the comparator. When this reaches the threshold voltage, the comparator output switches low and power NM turns off. The comparator output also drives another NMOS switch, which bypasses internal resistor R3 to provide a controlled amount of hysteresis. The hysteresis is set by R3 to be nominally 15%. When power NM is off, the current in L1 continues to flow via D1 and the LED(s) back to V<sub>IN</sub>. The current decays at a rate determined by the LED and diode forward voltages to produce a falling voltage at the input of the comparator. When this voltage returns to 1.2V, the comparator

output switches high again. This cycle of events repeat, with the comparator input ramping between limits of  $1.2V \pm 15\%$ .

### SWITCHING THRESHOLDS

The ratios of R1, R2 and R3, define an average  $V_{CSN}$  switching threshold of 100mV (measured on the CSN pin with respect to  $V_{IN}$ ). The average output current  $I_{OUTavg}$  is then defined by this voltage and  $R_S$  according to:

$$I_{OUTavg} = 100mV/R_S$$

Nominal ripple current is  $\pm 15mV/R_S$

### OUTPUT SHUTDOWN

When the input voltage to this circuit falls below the threshold, the internal circuits are turned off. Quiescent supply current during shutdown is nominally 75 $\mu$ A and switch leakage is below 1 $\mu$ A.

### UNDER-VOLTAGE LOCKOUT (UVLO)

The CE9302 include UVLO with 500mV hysteresis. The internal MOSFET turns off when  $V_{IN}$  falls below 5.7V.

### DIM INPUT

The CE9302 allow dimming with a PWM signal at the DIM input. A logic level below 0.3V at DIM forces CE9302 to turn off the LED and the logic level at DIM must be at least 2.5V to turn on the full LED current. The frequency of PWM dimming ranges from 100Hz to more than 20kHz.

The DIM pin can be driven by an external DC voltage ( $V_{DIM}$ ) to adjust the output current to a

value below the nominal average value defined by  $R_S$ . The DC voltage is valid from 0.5V to 2.5V. When the dc voltage is higher than 2.5V, the output current keeps constant.

The LED current also can be adjusted by a resistor connected to the DIM pin. An internal pull-up resistor (typical 500k $\Omega$ ) is connected to a 5.3V internal regulator. The voltage of DIM pin is divided by the internal and external resistor.

The DIM pin is pulled up to the internal regulator (5.3V) by a 500k $\Omega$  resistor. It can be floated at normal working. When a voltage applied to DIM falls below the threshold (0.3V nom.), the output switch is turned off. The internal regulator and voltage reference remain powered during shutdown to provide the reference for the shutdown circuit. Quiescent supply current during shutdown is nominally 75 $\mu$ A and switch leakage is below 1 $\mu$ A.

### THERMAL SHUTDOWN

The CE9302 thermal shutdown feature turns off the SW driver when the junction temperature exceeds +160 $^{\circ}$ C. The SW driver turns back on when the junction temperature drops 15 $^{\circ}$ C below the shutdown-temperature threshold.

### INHERENT OPEN-CIRCUIT LED PROTECTION

If the connection of the LED(s) is open circuited, the coil is isolated from the SW pin of the chip, so the device will not be damaged, unlike in many boost converters, where the back EMF may damage the internal switch by forcing the drain above its breakdown voltage.

## ■ APPLICATION INFORMATION

The basic CE9302 application circuits are shown in Figure 1. External component selection is

driven by the load requirement and begins with the selection of L followed by  $C_{IN}$  and  $C_{OUT}$ .

### INPUT CAPACITOR SELECTION

Ceramic capacitors are the best choice for the input to the CE9302 due to their high ripple current rating, low ESR, low cost, and small size compared to other types. When selecting a ceramic capacitor, special attention must be paid to the operating conditions of the application. Ceramic capacitors can lose one-half or more of their capacitance at their rated DC voltage bias and also lose capacitance with extremes in temperature. A DC voltage rating equal to twice the expected maximum input voltage is recommended. Surface mount X5R or X7R ceramic capacitors are suggested for input capacitor. In general, a 1 $\mu$ F ceramic type capacitor is enough for stable operation.

### OUTPUT CAPACITOR SELECTION

The buck converter is unique among non-isolated topologies because of the direct connection of the inductor to the load during the entire switching cycle. By definition an inductor will control the rate of change of current that flows through it, and this control over current ripple forms the basis for component selection in both voltage regulators and current regulators. A current regulator such as the LED driver for which the CE9302 was designed focuses on the control of the current through the load, not the voltage across it. A constant current regulator is free of load current transients, and has no need of output capacitance to supply the load and maintain output voltage.

A capacitor placed in parallel with the LED(s) can be used to reduce the LED current ripple while keeping the same average current through both the inductor and the LED array. With an output capacitor, the output inductance can be

lowered, making the magnetics smaller and less expensive. Alternatively, the circuit could be run at lower frequency but keep the same inductor value, improving the power efficiency. The over current comparator still monitor peak inductor current, placing a limit on how large  $\Delta i_L$  can be even if  $\Delta i_F$  is made very small. Adding a capacitor that reduces  $\Delta i_F$  to well below the target provides headroom for changes in inductance or  $V_{IN}$  that might otherwise push the peak LED ripple current too high. For most LEDs, a 10 $\mu$ F 100V ceramic capacitor (X5R or X7R) at the output results in very low output voltage ripple and good transient response. Other types and values will also work but may harm efficiency more or less.

### INDUCTOR SELECTION

The CE9302 is designed to operate with a 47 $\mu$ H inductor for all input/output voltage combinations. The inductor saturation current rating should be greater than the NMOS current limit specification listed in the Electrical Characteristics table. If necessary, the peak inductor current can exceed the saturation level by a small amount with no significant effect on performance.

Following table gives the guideline on inductor selection:

Load current	Inductor	Saturation current
1000mA	22 $\mu$ H	1.3-1.5 times of load current
700mA	47 $\mu$ H	
350mA	100 $\mu$ H	

Different core materials and shapes will change the size/current and price/current relationship of an inductor. The choice of which

style inductor to use often depends more on the price vs. size requirements and any radiated field/EMI requirements than on what the CE9302 requires to operate. Table 2 shows some typical surface mount inductors that work well in CE9302 applications.

Table 2. Representative Surface Mount Inductors

PART NUMBER	VALUE (μH)	MAX DCR (mΩ)	MAX DC CURRENT (mA)
CoilCraft DO1608C	47	640	500
Taiyo Yuden NP04SB470M	47	270	380
CoilCraft MSS6132ML	100	390	830

## OUTPUT DIODE

The CE9302 is a non-synchronous buck regulator that requires a recirculating diode D1 to carrying the inductor current during the MOSFET off-time. The most efficient choice for D1 is a Schottky diode due to low forward drop and near-zero reverse recovery time. D1 must be rated to handle the maximum input voltage plus any switching node ringing when the MOSFET is on. In practice all switching converters have some ringing at the switching node due to the diode parasitic capacitance and the lead inductance. D1 must also be rated to handle the average current,  $I_D$ , calculated as:

$$I_D = (1 - D) \times I_F$$

This calculation should be done at the maximum expected input voltage. The overall converter efficiency becomes more dependent on the selection of D1 at low duty cycles, where the recirculating diode carries the load current for an increasing percentage of the time. This power dissipation can be calculating by checking the typical diode forward voltage,  $V_D$ , from the I-V

curve on the product datasheet and then multiplying it by  $I_D$ . Diode datasheets will also provide a typical junction-to-ambient thermal resistance,  $\theta_{JA}$ , which can be used to estimate the operating die temperature of the device. Multiplying the power dissipation ( $P_D = I_D \times V_D$ ) by  $\theta_{JA}$  gives the temperature rise. The diode case size can then be selected to maintain the Schottky diode temperature below the operational maximum.

## LED RIPPLE CURRENT

Selection of the ripple current,  $\Delta I_F$ , through the LED array is similar to the selection of output ripple voltage in a standard voltage regulator. Where the output ripple in a voltage regulator is commonly  $\pm 1\%$  to  $\pm 5\%$  of the DC output voltage, LED manufacturers generally recommend values for  $\Delta I_F$  ranging from  $\pm 5\%$  to  $\pm 20\%$  of  $I_F$ . Higher LED ripple current allows the use of smaller inductors, smaller output capacitors, or no output capacitors at all. Lower ripple current requires more output inductance, higher switching frequency, or additional output capacitance, and may be necessary for applications that are not intended for human eyes, such as machine vision or industrial inspection.

## SETTING THE LED CURRENT

Figure1 shows the basic application circuit of the CE9302. The LED current is programmed with a current-sense resistor connected between  $V_{IN}$  and CSN pin. It's recommended to use a 1% or better precision resistor for the better LED current accuracy. The external resistor sets the LED current according to the following equation:

$$R_S = 100\text{mV} / I_{LED}$$



Table 3.  $R_S$  Resistor Value Selection

Resistor	$I_{LED}(mA)$
0.29	350
0.15	700

### DIMMING CONTROL

LED brightness dimming can be done by applying a PWM signal to the EN input. The LED current is repetitively turned on and off, so that the average current is proportional to the duty cycle. A 0% duty cycle will turn off the CE9302 and corresponds to zero LED current. A 100% duty cycle, with EN always high, corresponds to the LEDs at nominal current. The recommended PWM frequency range is from 100Hz to 50kHz.

### OPERATION AT LOW SUPPLY VOLTAGE

The internal regulator disables the drive to the switch until the supply has risen above the startup threshold. Above this threshold, the device will start to operate. However, with the supply voltage below the specified minimum value, the switch duty cycle will be high and the device power dissipation will be at a maximum. Care should be taken to avoid operating the device under such conditions in the application, in order to minimize the risk of exceeding the maximum allowed die

temperature. Note that when driving loads of two or more LEDs, the forward drop will normally be sufficient to prevent the device from switching below approximately 6V. This will minimize the risk of damage to the device.

### PCB LAYOUT GUIDANCE

Careful PCB layout is critical to achieve low switching losses and stable operation. Use a multilayer board whenever possible for better noise immunity. Minimize ground noise by connecting high-current ground returns, the input bypass-capacitor ground lead, and the output-filter ground lead to a single point (star ground configuration). In normal operation, there are two power loops. One is formed when the internal MOSFET is on and the high current flows through  $V_{IN}$ ,  $R_S$ , LED load, the inductor, the internal MOSFET, and GND. The other loop is formed when the internal MOSFET is off and the high-current circulates through  $R_S$ , LED load, the inductor, and the recirculating diode. Minimize each loop area to reduce noise interaction. Place  $R_S$  as close as possible to CSN pin and  $V_{IN}$  pin. For better noise immunity, a Kelvin connection between CSN pin and  $R_S$  is strongly recommended.

- PACKAGING INFORMATION
- SOT-89-5 Package Outline Dimensions

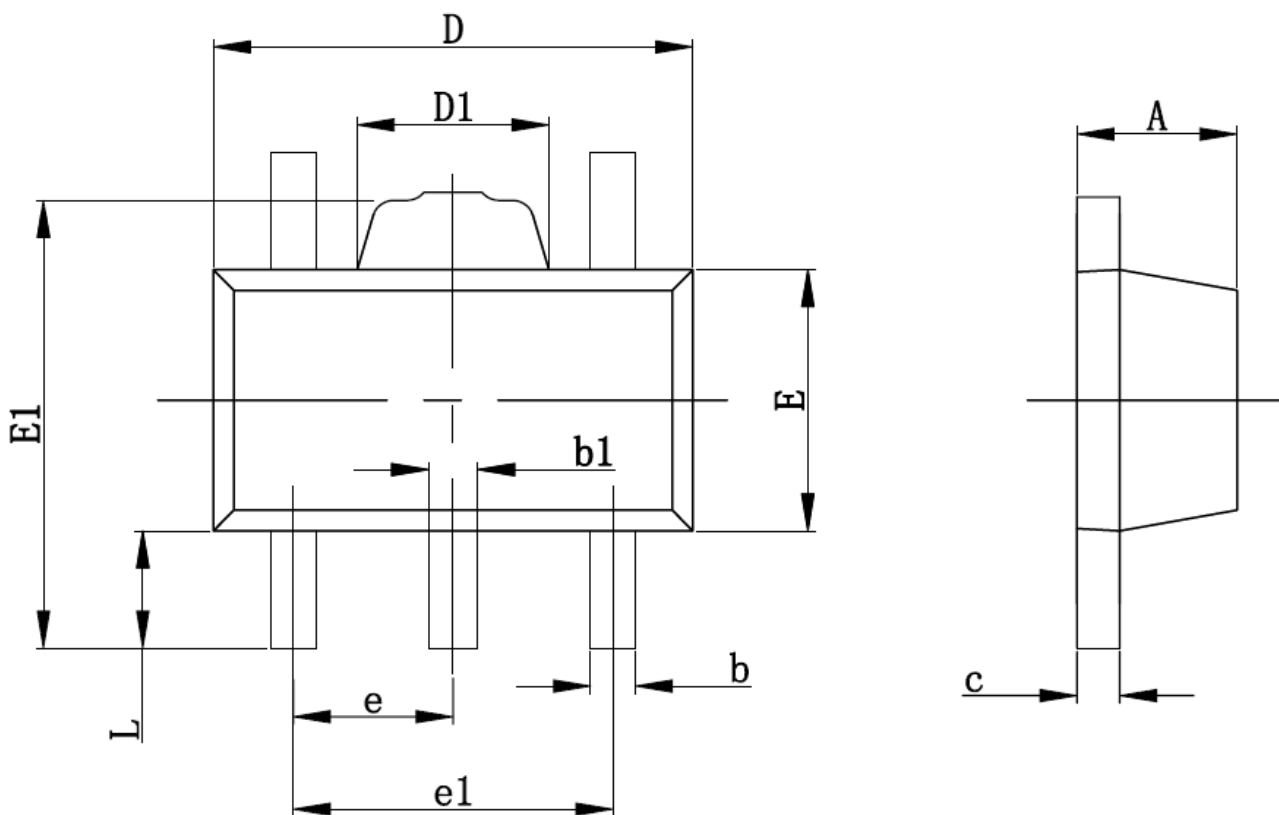

Symbol	Dimensions In Millimeters		Dimensions In Inches	
	Min	Max	Min	Max
A	1.400	1.600	0.055	0.063
b	0.320	0.520	0.013	0.020
b1	0.360	0.560	0.014	0.022
c	0.350	0.440	0.014	0.017
D	4.400	4.600	0.173	0.181
D1	1.400	1.800	0.055	0.071
E	2.300	2.600	0.091	0.102
E1	3.940	4.250	0.155	0.167
e	1.500 (TYP)		0.060 (TYP)	
e1	2.900	3.100	0.114	0.122
L	0.900	1.100	0.035	0.043

● SOP8-PP Package Outline Dimensions

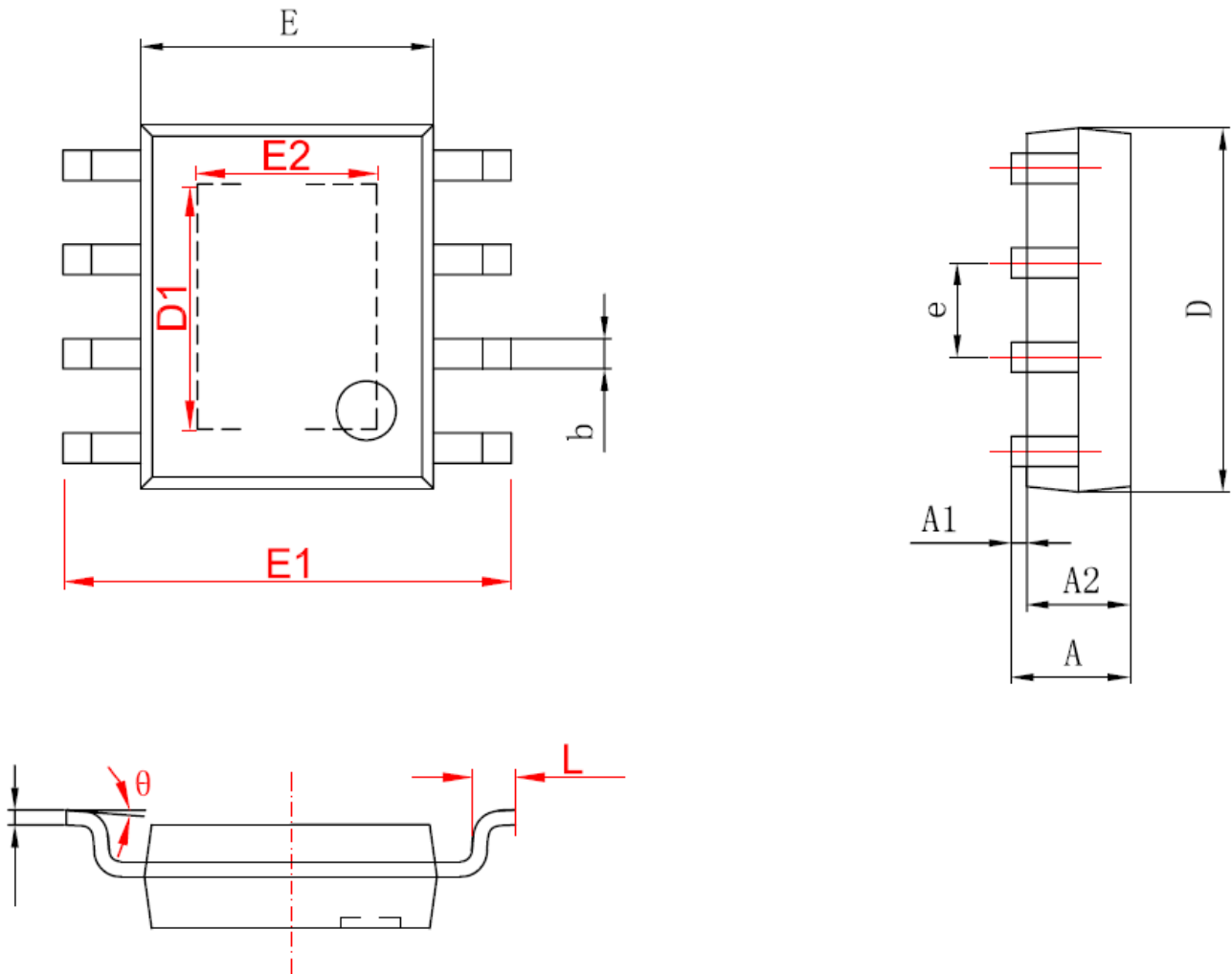

Symbol	Dimensions In Millimeters		Dimensions In Inches	
	Min	Max	Min	Max
A	1.350	1.750	0.053	0.069
A1	0.050	0.150	0.004	0.010
A2	1.350	1.550	0.053	0.061
b	0.330	0.510	0.013	0.020
c	0.170	0.250	0.006	0.010
D	4.700	5.100	0.185	0.200
D1	3.202	3.402	0.126	0.134
E	3.800	4.000	0.150	0.157
E1	5.800	6.200	0.228	0.244
E2	2.313	2.513	0.091	0.099
e	1.270 (TYP)		0.050 (TYP)	
L	0.400	1.270	0.016	0.050
θ	0°	8°	0°	8°

© Nanjing Chipower Electronics Inc.

Chipower cannot assume responsibility for use of any circuitry other than circuitry entirely embodied in a Chipower product. No circuit patent license, copyrights or other intellectual property rights are implied. Chipower reserves the right to make changes to their products or specifications without notice. Customers are advised to obtain the latest version of relevant information to verify, before placing orders, that information being relied on is current and complete.